

PART NO.	"A" REF.	"B" REF.	"C" REF.	"D"	"E"
PFC-25M	.189 [4.8]	.494 [12.55]	.437 [11.1]	.38±.020 [9.7]	.75 [19.1]
PFC-50M	.205 [5.2]	.573 [14.55]	.555 [14.1]	.55 [14.1]	.98 [25]

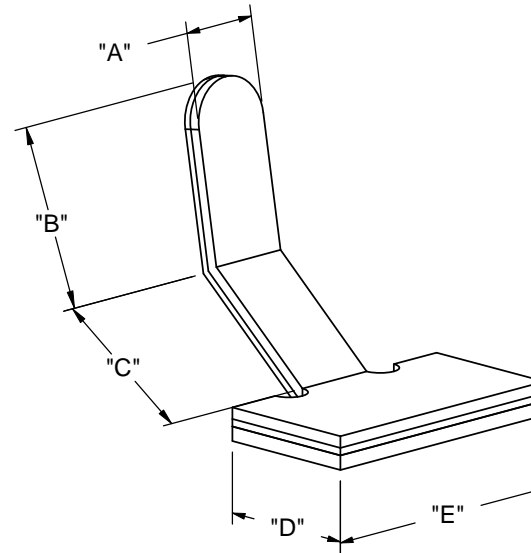
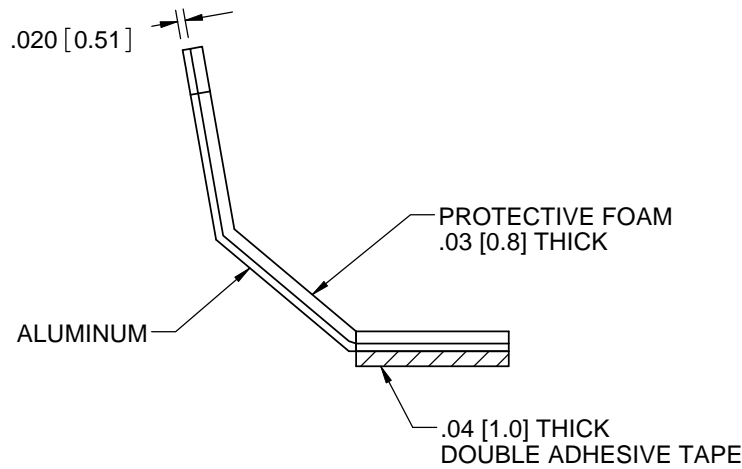

- NOTES:
 1. MATERIAL: ALUMINUM (RMS-194).
 2. POLYETHYLENE ADHESIVE FOAM TAPE (RMS-93).
 3. POLYETHYLENE FOAM COATING (RMS-264).

K	SEE CO 200226 FOR CHANGES	SK	07/31/08
J	SEE CO 200195 FOR CHANGES	SK	06/02/08
I	SEE ECN #1307 FOR CHANGES	SK	04/04/07
H	SEE ECN #1254 FOR CHANGES	SK	11/29/06
G	SEE ECN #1011 FOR CHANGES	SK	06/02/05
F	SEE ECN #954 FOR CHANGES	SK	03/01/05
E	SEE ECN #895 FOR CHANGES	SM	12/15/04
-	SEE ENGINEERING FOR REV. A-D	---	---
REV.	DESCRIPTION	ENGR.	DATE

TITLE: PLASTIC FOAM COATED CLIP				DWG IN IN [MM]	QR
CREATED USING SOLIDWORKS	FILE #: PFC	DWN: SM	APP: SM	FINAL	
TOLERANCES UNLESS NOTED .XX=±.010 .XXX=±.005 FRAC.=±1/64 ANG.=±1°	SHEET: 1 OF 1	SHEET SIZE: A	DT: 12/15/04	CHKD: SJ	PART #
	RE: RICHCO, INC.	RICHCO, INC. ENG@RICHCO-INC.COM (773) 539-4060	SEE TABLE	PRINT TYPE	CA